

W Band Differential IQ Transmitter, 88-100GHz, High Power, High Gain, WR-10

2022-12-1

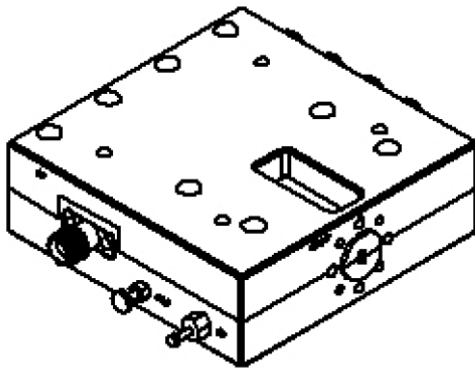

Product Overview

AT-WTX-88100IQD is a W-Band differential IQ Transmitter. The Tx is integrated with High Performance GaAs MMIC chips. RF frequency range is 88-100GHz, LO range is 11-12.5GHz with x8 times multiplier inside. IF range is DC-10GHz.

The Tx Module is with compact size. LO/IF port is with SMA, and RF port is with standard WR-10.

More information, please visit www.atmicrowave.com

Feature

- ✓ Frequency: 88-100GHz
- ✓ High Power: +18dBm
- ✓ High Gain: 15dB
- ✓ IF Range: DC-10GHz
- ✓ Single power supply

Application

- ✓ W Band Communication
- ✓ FOD (Foreigner Objects Debris)
- ✓ Test Equipment
- ✓ ROF (RF Over Fiber)
- ✓ Radar System

Diagram Block

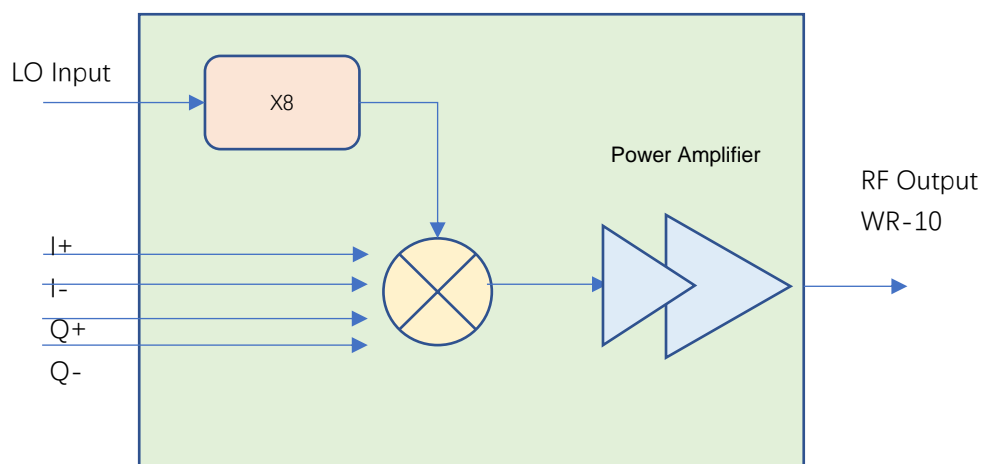



AT-WTX-88100IQD

W Band Differential IQ Transmitter

Key Features

Parameter	Min	Typical	Max
RF Frequency		88-100GHz	
IF to RF Gain(IF=100MHz)	12dB	15dB	
IF Frequency		DC-10GHz	
LO Frequency		11-12.5GHz	
LO Multiplier Factor		X8	
LO Power	0	+3dBm	+5dBm
P1dB		+15dBm	
Psat		+17dBm	
Power Supply		+5V	+8V
Current		0.5A	
Spec Temp		25C	





AT-WTX-88100IQD

W Band Differential IQ Transmitter

Mechanical Information

Parameter	Description
RF Port	WR-10
LO Port	SMA Female
IF Port	SMA Female
Case Material (Note)	Copper
Finish	Gold Plated
Weight	450g
Dimension	See outline

Note: Aluminium for lighter weight is available according to request

Absolute Maximum Ratings Table

Parameter	Value
IF Power	+7dBm/channel
LO Port	+15dBm
Power Supply	+7V
Operating Temperature	0 to +50C
Storage Temperature	-55 to +125C



Application Note

Mixer is a three port component with RF, LO and IF ports. Normally, a mixer can be used both up and down converter application. Take up converter for example:

General Balance Mixer

For general balance mixer, $RF = LO \pm IF$. There will be both high end $LO+IF$ and Low End $LO-IF$. Take for example, $IF=2GHz$, $LO=94GHz$, so there will be 88GHz and 96GHz at RF port with same power level.

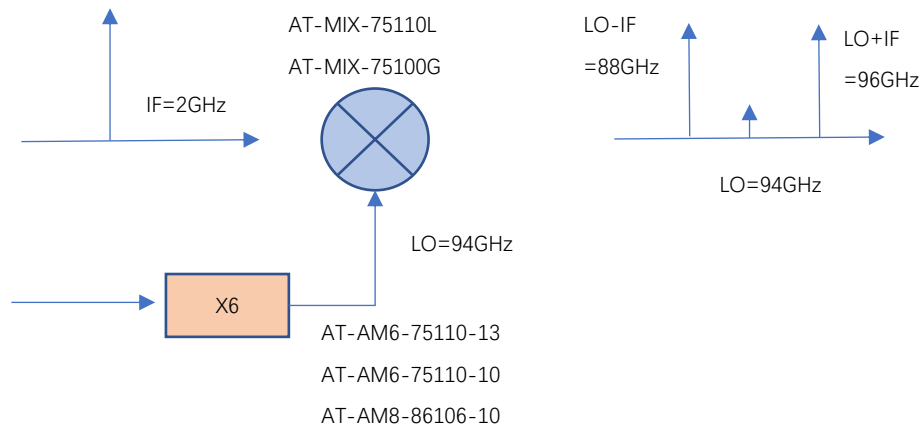

Figure A: General Balance Mixer with Both High and Low Side Output

IQ Mixer used as side suppression Mixer

When $IF=2GHz$, 90 degree hybrid is used at IF port, and IF applies to Input 1 Port of hybrid, you will have high end frequency $RF=LO+IF=96GHz$, while have side suppression (say $-25dBc$) at Low end frequency 88GHz.

When you need low end frequency 88GHz, and make side suppression for high end frequency 96GHz, just applies IF to Input 2 of the hybrid.

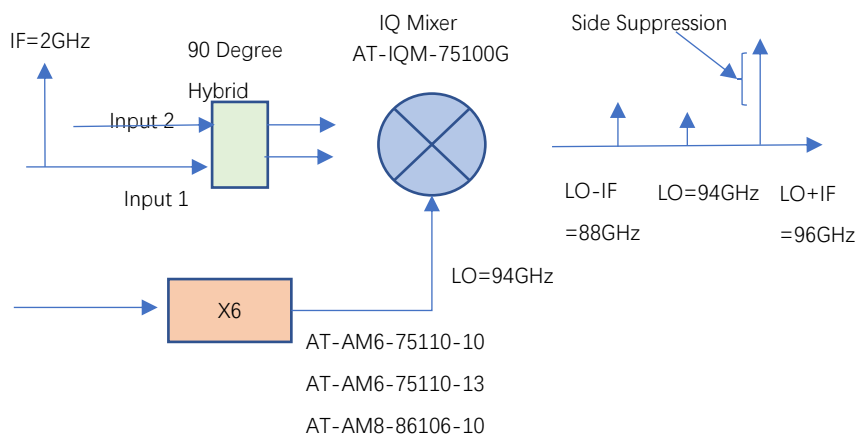

Figure B: IQ Mixer works as side suppression mixer



Dimension (unit mm)

