

Q Band: 33-50GHz IQ Mixer



Description:

AT-IQM-3350H is an up and down IQ mixer covering Q band based on GaAs MMIC Technology.

IF input is IQ port and can range from DC to 20GHz. LO/RF frequency range is 33-50GHz. LO RF isolation features 30DB. The imaging rejection is 35dB typical.

More information, please visit www.atmicrowave.com

Feature

- ✓ RF/LO: 33-50GHz
- ✓ IF: DC-20GHz
- ✓ Low Conversion Loss
- ✓ High RF/LO Isolation

Application

- ✓ Q band Communication
- ✓ Test Equipment
- ✓ ROF (RF Over Fiber)
- ✓ Radar System

Electronical Specifications:

Parameter	Min	Typical	Max
RF/LO Frequency		33-50GHz	
IF Range		DC-20GHz	
Conversion Loss		-10dB	-15dB
LO Driver	+15	+18dBm	+21
Input P1db		+10dBm	
IIP3		+20dBm	
Imaging Rejection		-30dB	
LO/RF Isolation		-30dB	
Spec Temp		25C	





AT-IQM-3350H

33-50GHz IQ Mixer

Mechanical Information

Item	Description
RF Port	WR-22
LO Port	WR-22
IF Port	SMA Female
Case Material	Copper
Finish	Gold Plated
Weight	30g
Size:	See outline

Absolute Maximum Ratings Table

Parameter	Value
IF Power	+15dBm
RF+LO Power	+25dBm
Operating Temperature	0 to +50C
Storage Temperature	-45 to +85C

Notes:

1. Datasheet may be changed according to update of MMIC, Raw materials , process, and so on.
2. This data is only for reference, not for guaranteed specifications.
3. Please contact AT Microwave team to make sure you have the most current data.



Application Note

Mixer is a three ports component with RF, LO and IF ports. Normally, a mixer can be used both up and down converter application. Take up converter for example:

General Balance Mixer

For general balance mixer, $RF=LO \pm IF$. There will be both high end $LO+IF$ and Low End $LO-IF$. Take for example, $IF=2GHz$, $LO=40GHz$, so there will be $38GHz$ and $42GHz$ at RF port with same power level.

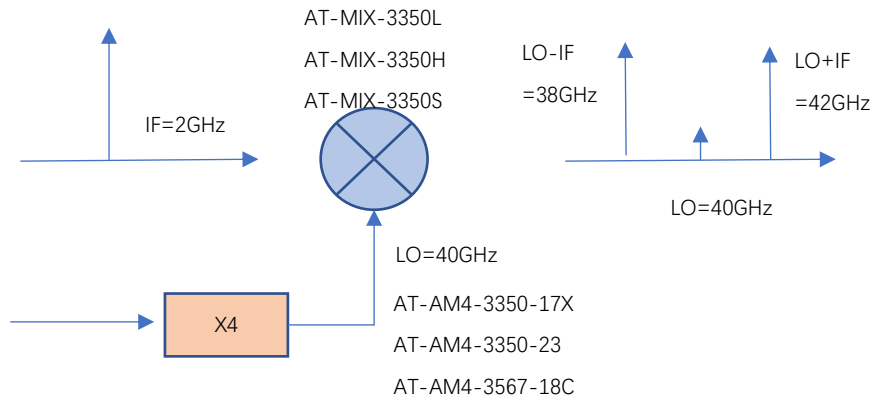

Figure A: General Balance Mixer with Both High and Low Side Output

IQ Mixer used as side suppression Mixer

When $IF=2GHz$, 90 degree hybrid is used at IF port, when IF applies to Input 1 Port of hybrid, you will have high end frequency $RF=LO+IF=42GHz$, while have side suppression (say $-25dBc$) at Low end frequency $38GHz$. When you need low end frequency $38GHz$, and make side suppression for high end frequency $42GHz$, just applies IF to Input 2 of the hybrid.

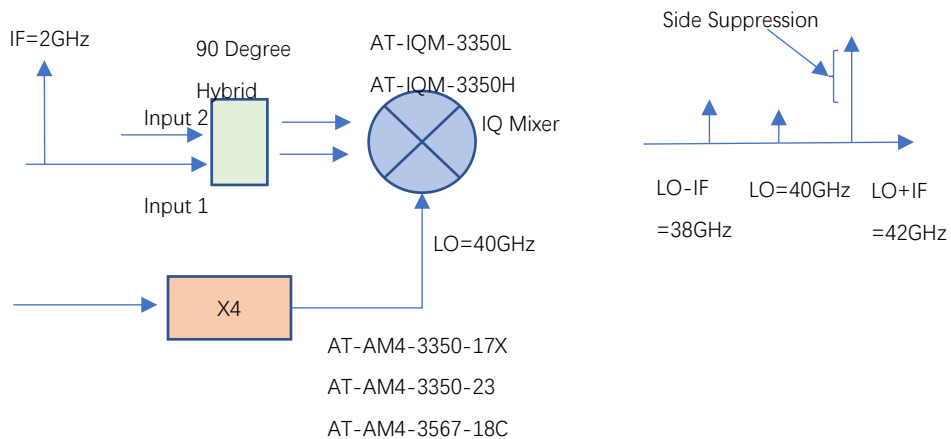

Figure B: IQ Mixer works as side suppression mixer

