

E Band Transmitter, 66-71GHz



Product Overview

AT-ETX-6671 is a V-Band Transmitter, with gain=12dB, Pout=+17dBm typical.

The Tx is integrated with High Performance GaAs MMIC chips. RF frequency range is 66-71GHz, LO range is 9.1-11.83GHz with x6 times multiplier inside. IF range is DC-10GHz The receive is with compact size. LO/IF port is with SMA, and RF port is with standard WR-12.

More information, please visit www.atmicrowave.com

Feature

- ✓ Frequency: 66-71GHz
- ✓ Gain: 12dB typical
- ✓ IF Range: DC-10GHz
- ✓ Pout: +17dBm Typical

Application

- ✓ V Band Communication
- ✓ FOD (Foreigner Objects Debris)
- ✓ Test Equipment
- ✓ ROF (RF Over Fiber)
- ✓ Radar System

Diagram Block

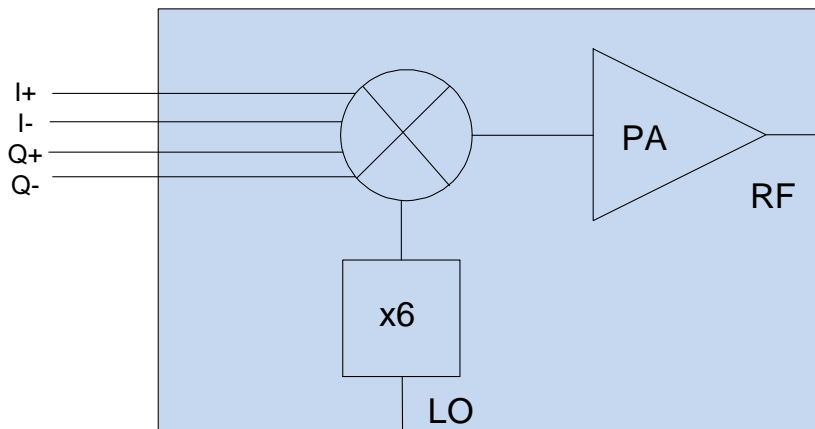



AT-ETX-6671

Compact E Band Transmitter, 66-71GHz

Key Features

Parameter	Min	Typical	Max
RF Frequency		66-71GHz	
IF Frequency		DC-10GHz	
LO Frequency	9.1GHz		11 . 83GHz
LO Multiplication Factor		X6	
LO Power		+10dBm	
P1Db		+15dBm	
Psat		+17dBm	
Conversion Gain		12 dB	
RF Return Loss		-12 dB	
LO Return Loss		-10 dB	
Drain Power Supply		+5/500mA	+8V
Spec Temp		25C	





AT-ETX-6671

Compact E Band Transmitter, 66-71GHz

Mechanical Information

Parameter	Description
RF Port	WR-15
LO Port	SMA Female
IF Port	SMA Female
Case Material (Note)	Copper
Finish	Gold Plated
Weight	315g
Dimension	See outline

Note: Aluminium for lighter weight is available according to request

Absolute Maximum Ratings Table

Parameter	Value
IF Power	+7dBm
LO Port	+15dBm
Power Supply	+7V
Operating Temperature	0 to +50C
Storage Temperature	-55 to +125C





AT-ETX-6671

Compact E Band Transmitter, 66-71GHz

Test Condition

Parameter	Setting
IF Input Power	-10dBm/ch
Input Frequency	1GHz
LO Power	+10dBm
Temperature	25C

Test Condition

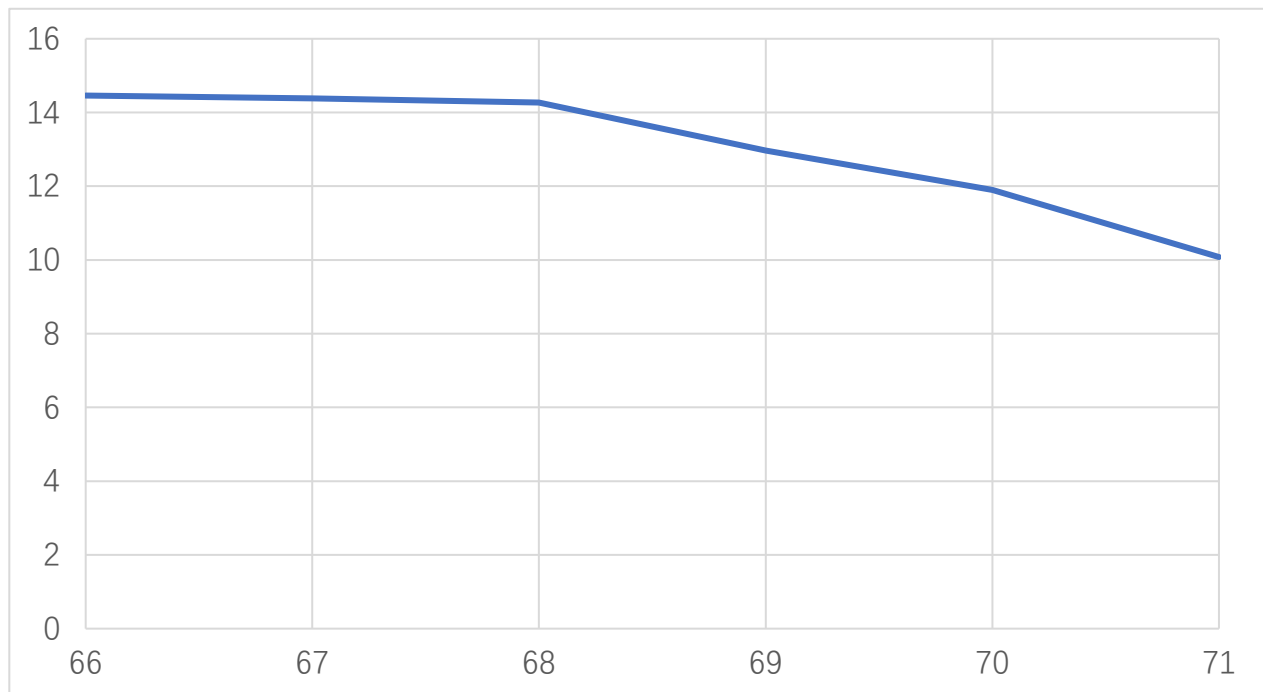

Conversion Gain vs Frequency





AT-ETX-6671

Compact E Band Transmitter, 66-71GHz

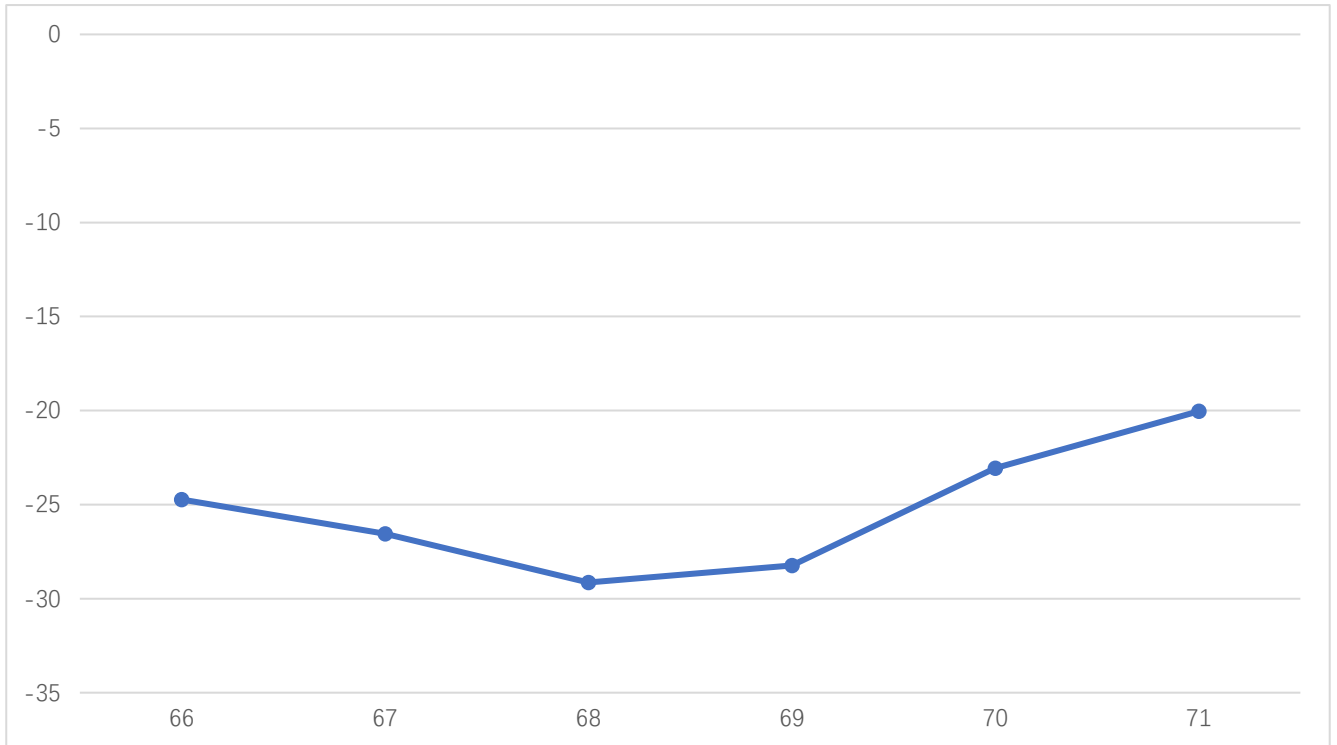

Low Band Suppression vs Frequency, IF=2GHz

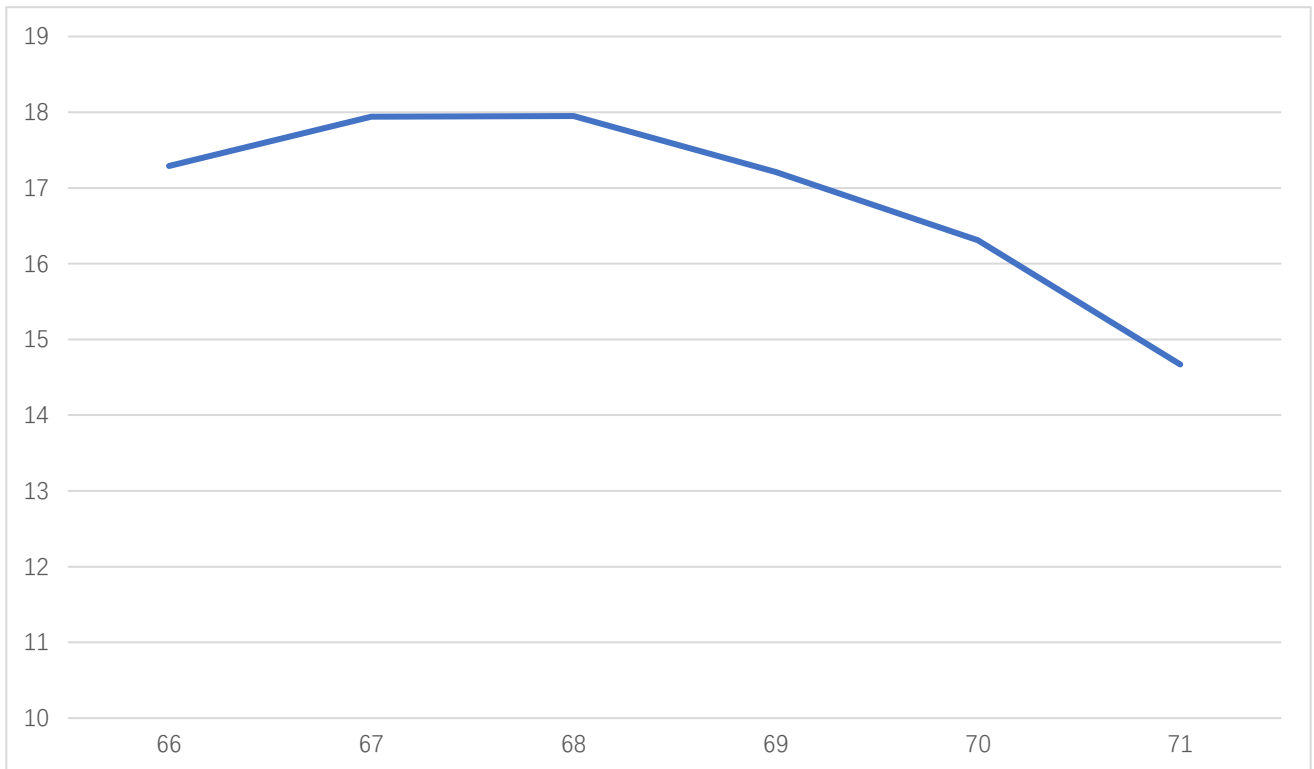

Pout vs Frequency



Applicaiton1:

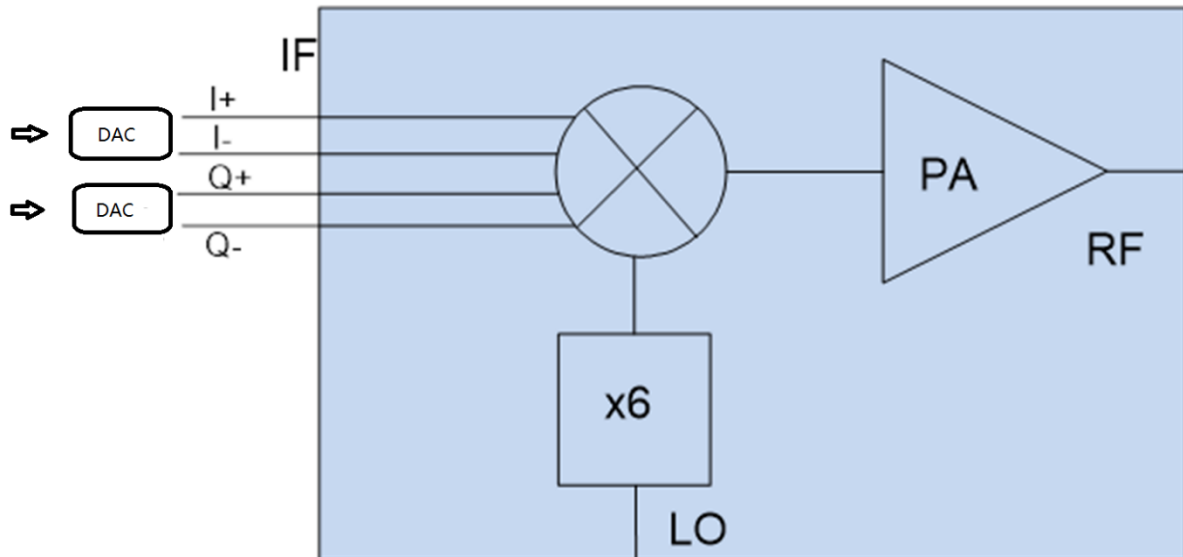

Zero IF Direct Conversion

Applicaiton2:

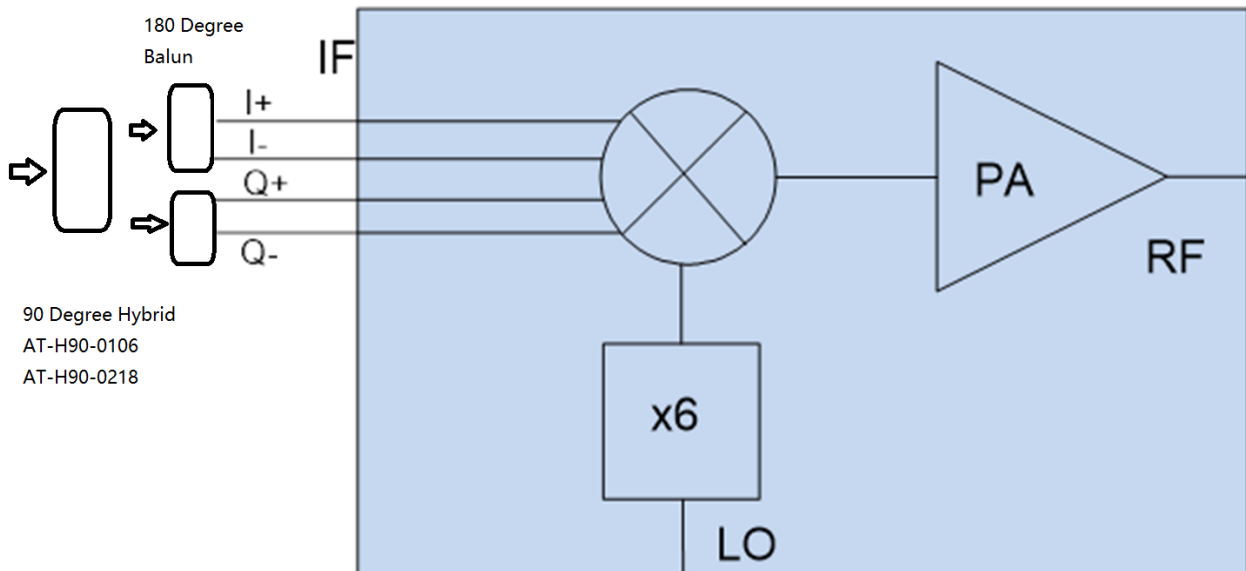

Imaging Rejection Single IF Application

Contact with us for 180degree balun and 90degree hybrid.



Application Note

Mixer is a three port component with RF, LO and IF ports. Normally, a mixer can be used both up and down converter application. Take up converter for example:

General Balance Mixer

For general balance mixer, $RF = LO \pm IF$. There will be both high end $LO+IF$ and Low End $LO-IF$. Take for example, $IF=2GHz$, $LO=80GHz$, so there will be $78GHz$ and $82GHz$ at RF port with same power level.

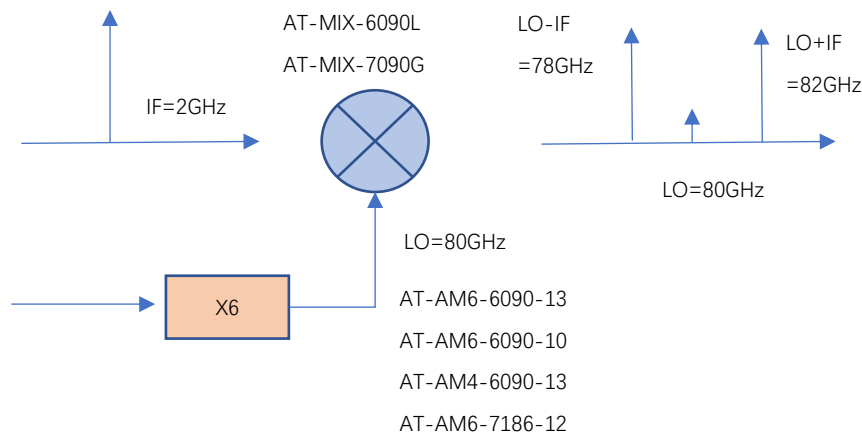

Figure A: General Balance Mixer with Both High and Low Side Output

IQ Mixer used as side suppression Mixer

When $IF=2GHz$, 90 degree hybrid is used at IF port, and IF applies to Input 1 Port of hybrid, you will have high end frequency $RF = LO + IF = 82GHz$, while have side suppression (say $-25dBc$) at Low end frequency $78GHz$.

When you need low end frequency $78GHz$, and make side suppression for high end frequency $82GHz$, just applies IF to Input 2 of the hybrid.

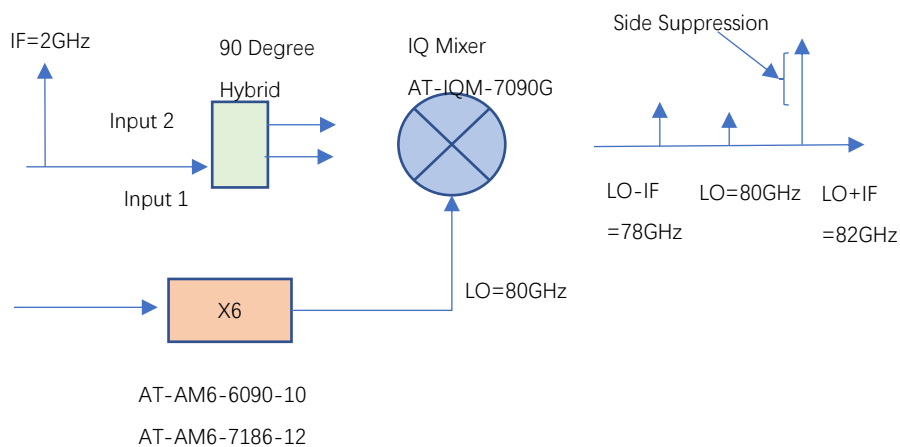

Figure B: IQ Mixer works as side suppression mixer



Dimension (mm)

